

RHM 03 a1 -

300 kg/hr

-200 ~ +400 C

868 bar, Size 1/4" ~ 1/2"

RHM 03
가

0.05 ~ 5 kg/min (11 lb/min),
가

-200 ~ 400 °C, 868 bar
(Rheonik)



GENERAL ()

RHM 03 10 가 , 가
가
(Coriolis)
가(Omega)
가
가 (torsion rod swinger)
(support bars)

APPLICATIONS ()

- Batching
- Dosing
- Injections
- Filling

FEATURES ()

- : 868 bar
- : 0.005 kg/min ~ 5 kg/min (11 lb/min)
- 가
- : 0.1%
- : 0.05%
- process connection.
- 가

ADVANTAGES ()

- 가
- 가
- (low stress in welds and increased wall thickness against abrasion)
- 가
- 가
- EEx (KOSHA97-2733-Q2)

RHM 03 a1

Max Flow 5 kg/min (11 lb/min)

1) Standard Models

Rates / turndown ratio	in kg/min	in lb/min	error in % of reading
nominal rate Q _{nom} :	5.000	11.03	0.20
0.2 *Q _{nom} (5: 1)	1.000	2.21	0.20
0.1 *Q _{nom} (10:1)	0.500	1.10	0.20
0.05 *Q _{nom} (20:1)	0.250	0.55	0.20
0.02 *Q _{nom} (50:1)	0.100	0.22	0.50

Typical ΔP in bar (psi)	
1 cP	100 cP
1.4 (20.3)	14.7 (213.2)
0.1 (1.5)	2.9 (42.1)
~0 (0.2)	1.5 (21.8)
~0 (0.1)	0.8 (11.6)
~0 (0)	0.3 (4.4)

2) Optimized Low Flow Models / optimized to be operated between 0.02 x Q_{max} and 0.4 x Q_{max}

0.4 *Q _{max} (1:1)	2.000	4.41	0.20
0.02 *Q _{max} (20:1)	0.100	0.22	0.20

0.3 (4.4)	5.6 (81.3)
~0 (0)	0.3 (4.4)

(*) serial/single path version offers the same accuracy at half the flow - 0.2% @ 0.05

3) Gold Line Models application fine tuned meters

1 *Q _{nom} (1:1)	5.000	11.03	0.10
0.2 *Q _{nom} (5:1)	1.000	2.21	0.12
0.1 *Q _{nom} (10:1)	0.500	1.10	0.15

1.4 (20.3)	14.7 (213.2)
0.1 (1.5)	2.9 (42.1)
~0 (0.2)	1.5 (21.8)

Repeatability better ± 0.05 % of rate
Temperature better ± 1°C

Standard Models

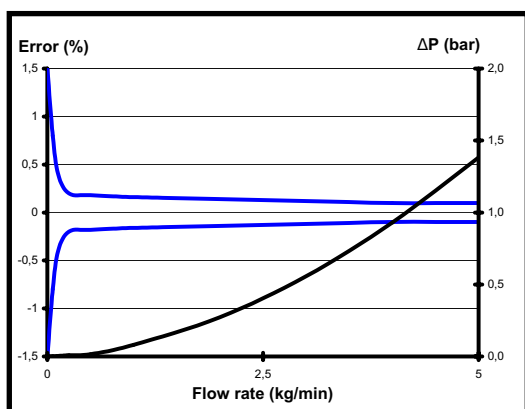

Gold Line Models

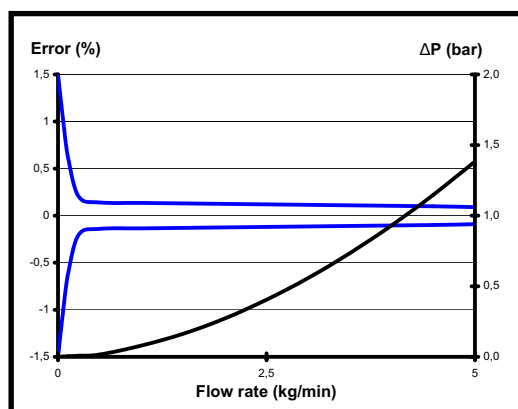

For serial (single pipe/path) sanitary design Q_{max} is 2.5 kg/min (50%)

Error of reading (including zero drift) indications refer to reference conditions H₂O, 18-24°C (66-76°F), 1-3 bar (15-45 psi)

Pressure drop refers to Newton liquids, with parallel measuring loops and block/manifold connection (low ΔP version)

Nominal flow refers to approx. 10 m/s (33 ft/sec) velocity in measuring loops for best performance

Calibration to customer range possible

RHM 03 a1

Type I (w/ removable manifold block - serial/parallel / PTFE seals)

thread type:

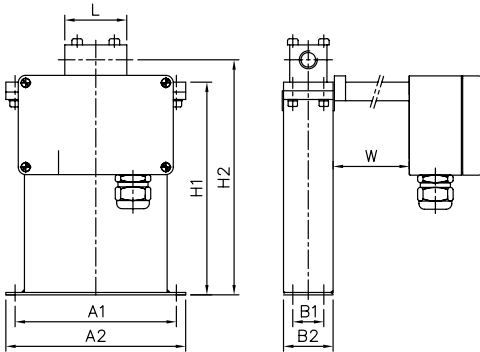

Weight approx. 2kg (4.4 lb)

flange type:

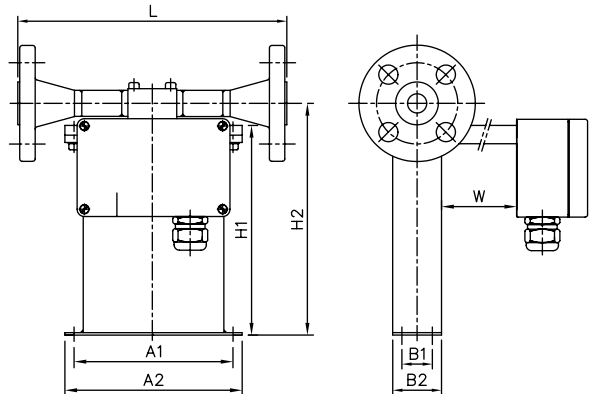

Weight approx. 4kg (8.8 lb)

A1=130 mm (5.12")
A2=145 mm (5.71")

B1=25 mm (0.98")
B2=40 mm (1.57")

H1=172 mm (6.77")
H2=188 mm (7.40")

W= 0 mm for NT models -20 to + 120°C (-4 to + 248°F)
= 100 mm (3.96") for extended and high temperature models

Process Connection for thread type		Face to face length (L)
Standard	G ¼" female	50 mm (1.97")
	NPT ¼" female	50 mm (1.97")
Optional	Autoclave	50 mm (1.97")
	M20 x 1.5	50 mm (1.97")

Process Connection for flange type		Face to face length (L)
Standard	½" / CL 150 acc. ANSI B16.5	220 mm (8.67")
	½" / CL 300 acc. ANSI B16.5	220 mm (8.67")
	½" / CL 600 acc. ANSI B16.5	220 mm (8.67")
	DN15 / PN40 acc. DIN 2635 - C	220 mm (8.67")
	DN15 / PN100 acc. DIN 2637 - E	220 mm (8.67")
Optional	½" / CL 900 acc. ANSI B16.5	300 mm (11.82")
	½" / CL 1500 acc. ANSI B16.5	300 mm (11.82")
	½" / CL 2500 acc. ANSI B16.5	300 mm (11.82")
	DN15 / PN160 acc. DIN 2638 - E	220 mm (8.67")
Specials	1" Graylock or equivalent hubb	220 mm (8.67")
	Swagelok male	220 mm (8.67")
	Novaswiss	220 mm (8.67")

Our standard seals are PTFE - Manifold block on request available without seals but with brazed connection
Above table only shows our general process fittings
For further customization with regard to special fittings and face to face length please contact your local agent
For high pressure applications (above 350-400 bar) connection block face to face dimension will be 70 mm (2.76")

RHM 03 a1

Type II (sealless welded, parallel measuring loops w/o seals)

flange type:

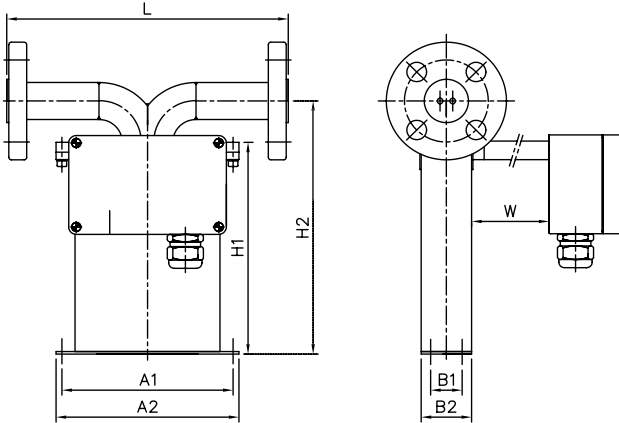

Weight approx. 4kg (8.8 lb)

special fittings:

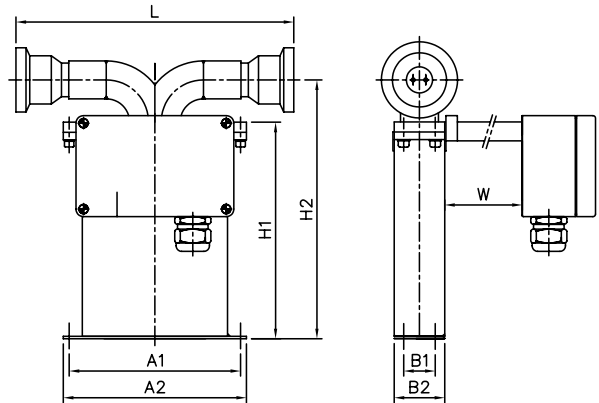

Weight approx. 4kg (8.8 lb)

A1=130 mm (5.12")
A2=145 mm (5.71")

B1=25 mm (0.98")
B2=40 mm (1.57")

H1=172 mm (6.77")
H2=205 mm (8.07")

W= 0 mm for NT models (-20 to + 120°C) (-4 to + 248°F)
= 100 mm (3.96") for extended and high temperature models

	Process Connection	Face to face length (L)
Standard	1/2" / CL 150 acc. ANSI B16.5	220 mm (8.67")
	1/2" / CL 300 acc. ANSI B16.5	220 mm (8.67")
	1/2" / CL 600 acc. ANSI B16.5	220 mm (8.67")
	DN15 / PN40 acc. DIN 2527 - C	220 mm (8.67")
	DN15 / PN100 acc. DIN 2527 - E	220 mm (8.67")
Optional	1/2" / CL 900 acc. ANSI B16.5	300 mm (11.82")
	1/2" / CL 1500 acc. ANSI B16.5	300 mm (11.82")
	1/2" / CL 2500 acc. ANSI B16.5	300 mm (11.82")
	DN15 / PN160 acc. DIN 2527 - E	220 mm (8.67")
Specials	Swagelok male	220 mm (8.67")
	1" Graylock or equivalent hubb	220 mm (8.67")

Above table only shows our general process fittings
For further customization with regard to special fittings and face to face length please contact your local agent

RHM 03 a1

Type III (sealless welded, serial measuring loops - single path w/o seals)

flange type:

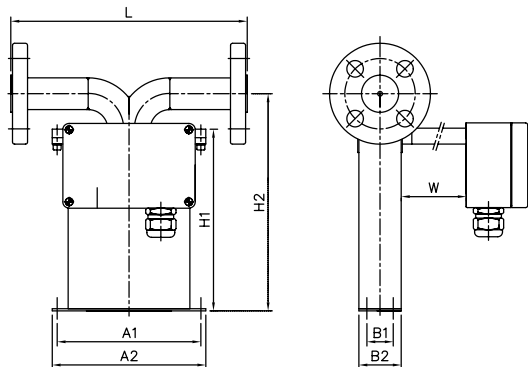

Weight approx. 4kg (8.8 lb)

special/sanitary fittings:

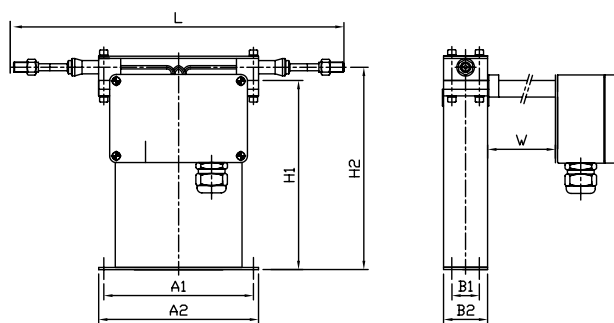

Weight approx. 4kg (8.8 lb)

A1=130 mm (5.12")
A2=145 mm (5.71")

B1=25 mm (0.98")
B2=40 mm (1.57")

H1=172 mm (6.77")
H2=205 mm (8.07") for flange type
H2=188 mm (7.40") for sanitary fittings

W= 0 mm for NT models (-20 to + 120°C) (-4 to + 248°F)
= 100 mm (3.96") for extended temperature models

	Process Connection	Face to face length (L)
Sanitary fittings	1/2" / Sanitary Tri Clamp acc. DIN 32676	190 mm (7.48")
	DN10 / Sanitary acc. DIN 11851	190 mm (7.48")
	FLO Clamp DN15	220 mm (8.67")
Flange	1/2" / CL 150 acc. ANSI B16.5	220 mm (8.67")
	1/2" / CL 300 acc. ANSI B16.5	220 mm (8.67")
	DN15 / PN40 acc. DIN 2527 - C	220 mm (8.67")
Specials	Swagelok male	please consult factory
	1/4" NPT male	please consult factory

Above table only shows our general process fittings
For further customization with regard to special fittings and face to face length please contact your local agent

RHM 03 a1

Temperature rating

- NT Models -20 to +120°C (-4 to +248°F)
- ET1 Models -200 to +50°C (-328 to +122°F)
- ET2 Models -45 to +210°C (-49 to +410°F)
- HT Models 0 to +350°C (+32 to +662°F)

Electrical connection

- Junction box / aluminium coated (standard) IP 65 (Nema 4X)
- Junction box in SS on request
- Cable entry M25 x 1.5 (½" and ¾" NPT optional)
- Max cable length between RHM and RHE:
100 m (330 ft)
200 m (660 ft) only with factory approval

Housing

- Stainless Steel: 1.4301 / SS 304
- other on request -
- Protection class: IP 65 (Nema 4X)
- higher on request -

Material of wetted parts

- 1.4539 / SS 904L (measuring loops)
- 1.4571 / SS 316Ti (process connection)
- Hastelloy C22 on request
- Tantalum on request
- Other materials optional as a special design

Pressure rating

- 300 bar @ 120°C (4350 psi @ 248°F)
- higher pressure on request -
- Optional low ΔP version with
150 bar @ 120°C (2175 psi @ 248°F)

(KOSHA97-2733-Q2)

- ATEX (CESI 02 ATEX 053 X):
Ex II 1 G, EEx ia IIC T6-T1
- CSA (220705)
Class I, Div 1 and 2,
Groups A, B, C and D; Type 3
- Custody Transfer Approvals
(PTB 1.32-97027224 and NMI TC 3382)
- PED according to directive 97/23/EC
available

RHEONIK Tel : 82-032-442-1515



For further information
please contact your
local representative