



Flowmeter Product Directory

MODEL : ASMA1



ASMA1-5-1-J-1

FEATURES

- 본 제품은 순간유량 측정과 경보, 접점(Alarm Signal) 기능을 부가한 제품으로 접점 신호는 1 점점과 2 점점으로 구분한다.
- 접점(Contact)을 설정하는 기구가 외부에서 조절(Adjust)할 수 있도록 설계 되어 경보 접점 위치를 수시로 이동하는 라인에서 사용하기에 최적이다.

SPECIFICATION

CON'N	SIZE	MAT'L	PRESS.	TEMP.	ACCURACY
FLANGE	15A-300A	STEEL	ST	10kgf/cm2	ST 120℃
		SUS304			
SCREW	15A-65A	SUS316	SP	40kgf/cm2	SP 200℃

ALARM CONTACT

CAPACITY	AC 220V 0.5A / DC 24V 0.05A
CONTACT OUTPUT	HIGH OR LOW SET ALARM
CONTACT TYPE	SENSOR SELF HOLDING FORM
CONTACT RATE	SPST RELAY OUTPUT
AMBIENT TEMP	-10 ~ 80℃
CABLE ENTRY	PF 1/2" FEMALE

MODEL CODE

ASMA1	—	<input type="checkbox"/>	—	<input type="checkbox"/>	—	<input type="checkbox"/>	—	<input type="checkbox"/>	DESCRIPTION
FLOW DIRECTION		1							BOTTOM - TOP
		5							SIDE - SIDE
		6							TOP - BOTTOM
MATERIAL				1					STEEL
				2					SUS304
				3					SUS316
				0					OTHER
CONNECTION						J			JIS 10K RF (FF)
						A			ANSI 150# RF (FF)
						D			DIN PN10/16
						P			PT(Male / Female)
						N			NPT(Male / Female)
						O			OTHER
CONTACT								1	ONE POINT ALARM
								2	TWO POINT ALARM



Flowmeter Product Directory

MODEL : ASMA1

FLOW RATE								
SIZE	DIVIDE	ALLOW RANGE			LENGTH (mm)			
		H ₂ O (m ³ /h)	AIR (Nm ³ /h) 0.5 kgf/cm ² G · 20°C	STEAM (kg/h) 3 kgf/cm ² G	M	N	L	
							FLANGE	SCREW
15A	1/2B	0.1 - 0.5	6 - 30	10 - 50	85	55	220	150
		0.4 - 2	12 - 60	20 - 100				
20A	3/4B	0.1 - 0.5	6 - 30	10 - 50	85	55	220	160
		0.4 - 2	12 - 60	20 - 100				
25A	1B	0.2 - 1	12 - 60	10 - 50	90	60	220	180
		1 - 5	30 - 150	40 - 200				
32A	1 1/4B	0.2 - 1	12 - 60	10 - 50	90	60	220	200
		1 - 5	30 - 150	40 - 200				
40A	1 1/2B	0.4 - 2	16 - 80	20 - 100	95	65	220	200
		2 - 10	60 - 300	80 - 400				
50A	2B	0.6 - 3	20 - 100	20 - 100	100	70	220	220
		3 - 15	90 - 450	120 - 600				
65A	2 1/2B	1.2 - 6	60 - 300	80 - 400	110	80	260	220
		6 - 30	180 - 900	240 - 1200				
80A	3B	1.6 - 8	120 - 600	100 - 500	110	80	300	
		8 - 40	240 - 1200	400 - 2000				
100A	4B	3 - 15	180 - 900	200 - 1000	130	100	330	
		16 - 80	400 - 2000	700 - 3500				
125A	5B	4 - 20	200 - 1000	200 - 1000	140	110	380	
		20 - 100	600 - 3000	900 - 4500				
150A	6B	6 - 30	240 - 1200		200	150	480	
		30 - 150	900 - 4500					
200A	8B	12 - 60	300 - 1500		210	180	650	
		60 - 300	1800 - 9000					
250A	10B	16 - 80	600 - 3000		230	200	680	
		80 - 400	2400 - 12000					
300A	12B	20 - 100	900 - 4500		280	250	720	
		100 - 500	3000 - 15000					

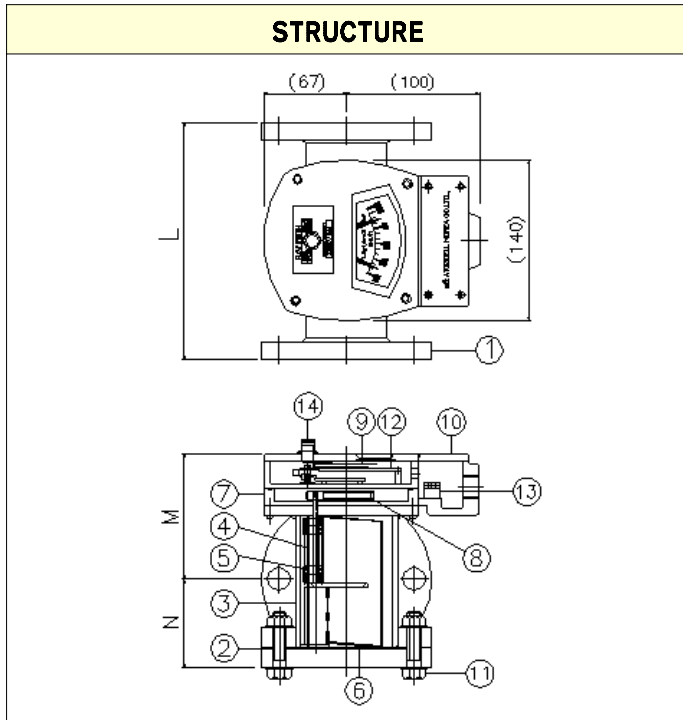

PART LIST

NO	NAME	MATERIAL		
		NO.1	NO.2	NO.3
1	Flange	SS400	SUS304	SUS316
2	Packing	NBR, EPDM, VITON, TEFLON		
3	Body	SPP	SUS304	SUS316
4	Shaft	SS	SUS304	SUS316
5	Spring	SUS304	SUS304	SUS316
6	Flapper	SS	SUS304	SUS316
7	Magnet Room	SUS304	SUS304	SUS316
8	Magnet	ALNICO		
9	Index	AL		
10	Cover	AL2		
11	Bolt Nut	STEEL	SUS304	SUS316
12	Sensor	REED S/W (PACKAGE)		
13	Terminal	ABS		
14	Index Adjust	MF.STAND		