



Flowmeter Product Directory

MODEL : ALE



ALE-W-3-1-W

FEATURES

- 본 제품은 순간유량 측정과 접점, 경보(Alarm Signal) 기능을 추가한 제품으로 접점신호는 1점점과 2 점점으로 구분 한다.
- 별도의 증폭부가 필요치 않다.
- Sensor는 자기 유지 기능을(Self Holding) 갖고 있다.

SPECIFICATION

CON`N	SIZE	MAT`L	PRESS.	TEMP.	ACCURACY
CLAMP	1S-4S	SUS304/316 SUS316L	10 kgf/cm ² (Max.)	150℃ (Max.)	FS±1.5%

ALARM CONTACT

Capacity	AC 220V 0.5A / DC 24V 0.05A
Contact Output	1 or 2 Point Alarm
Contact Type	Sensor Self Holding Form
Contact Rate	SPST Relay Output
Cable Code	0.4m (10m available)
Ambient Temp.	-20℃ ~ 80℃

MODEL CODE

ALE	—	□	—	□	—	□	—	□	DESCRIPTION
ACCESSORY		W							WITHOUT
		S							COCK VALVE
		C							CONNECTOR
MATERIAL				2					SUS304
				3					SUS316
				3L					SUS316L
				O					OTHER
CONTACT						W			WITHOUT
						1			ONE POINT ALARM
						2			TWO POINT ALARM
CONNECTION							E		FERRULE For EXPANDING
							W		FERRULE For WELDING
							O		OTHER



Flowmeter Product Directory

MODEL : ALE

FLOW RATE						
SIZE (d)		H ₂ O(m ³ /h)		AIR (Nm ³ /h) 760mmHg(A) 20℃		Length (mm)
		Flow Rate	One Scale	Flow Rate	One Scale	
1S	50.5	0.4~2.0	0.02	5~23	0.2	520
1 1/2S	50.5	0.8~4.0	0.1	8~40	1	520
2S	64	1.8~9.4	0.2	18~90	2	520
2 1/2S	77.5	3.5~18.5	0.5	35~175	5	540
3S	91	6~30	1	60~300	10	540
4S	119	8~40	1	80~400	10	540

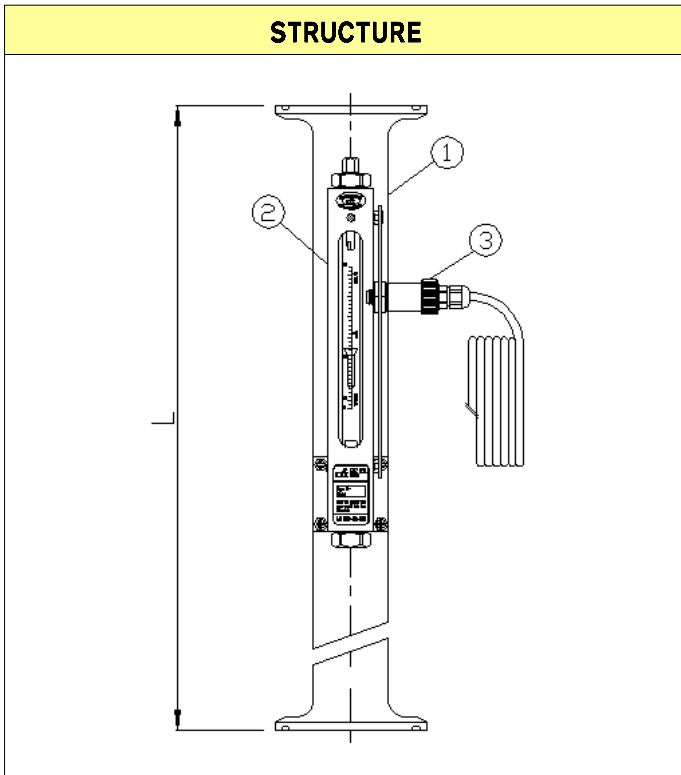

PART LIST

NO	NAME	MATERIAL		
		NO.2	NO.3	NO.3L
1	Body	SUS304	SUS316	SUS316L
2	Indicator	SUS304	SUS316	SUS316L
3	Sensor	AL(MFS. PACKAGE)		

